

Fasttape

Streaming Tape Drive for the Amiga®

This equipment generates and uses radio frequency energy and if not installed and used properly, that is, in strict accordance with the manufacturer's instructions, may cause interference to radio and television reception. It has been type tested and found to comply with the limits of a Class B computing device in accordance with the specifications in Subpart J of Part 15 of FCC Rules, which are designed to provide reasonable protection against such interference in a residential installation. However, there is no guarantee that interference will not occur in a particular installation. If this equipment does cause interference to radio or television reception, which can be determined by turning the equipment off and on, the user is encouraged to try to correct the interference by one or more of the following measures:

- Reorient the receiving antenna
- Relocate the computer with respect to the receiver
- Move the computer away from the receiver
- Plug the computer into a different outlet so that computer and receiver are on different branch circuits

If necessary, the user should consult the dealer or an experienced radio/television technician for additional suggestions. The user may find the following booklet prepared by the Federal Communications Commission helpful: "How to Identify and Resolve Radio-TV Interference Problems." This booklet is available from the U.S. Government Printing Office, Washington, D.C., 20402, Stock No. (X4-000-00345-4).

Xetec FastTape programs and manual written by Mary Flickinger

FastTape diskette copyright © 1989
All rights reserved.

AmigaDOS, Kickstart, Intuition, and Workbench are all trademarks of Commodore-Amiga, Inc.
Amiga is a registered trademark of Commodore-Amiga, Inc.

SECOND PRINTING December 1989
Copyright © 1989 by Xetec, Inc.
891204

All specifications subject to change without notice.

*Fast*tape™

Streaming Tape Drive for the Amiga®



2804 Arnold Rd
Salina, KS 67401
(913) 827-0685

LIMITED WARRANTY

Xetec, Inc. warrants this tape drive known as the *FastTape* to be in good working order for a period of nine months from the date of purchase from Xetec, Inc. or an authorized dealer. All parts except the tape drive itself are warranted for a full year. Should this product fail to be in good working order at any time during this warranty period, Xetec will, at its option, repair or replace this product with no additional charge except as set forth below. Repair parts and replacement products will be furnished on an exchange basis and will be either reconditioned or new. All replaced parts and products become the property of Xetec, Inc. This limited warranty does not include service to repair damage to the product resulting from accident, disaster, abuse, or non-Xetec modification of the product.

Limited warranty service may be obtained by delivering the product during the warranty period to an authorized Xetec dealer or to Xetec, Inc., and by providing proof of purchase date. Warranty will be valid for registered owners only. If this product is delivered by mail, you agree to insure the product or assume the risk of loss or damage in transit, to prepay shipping charges to Xetec, Inc., and to use the original shipping container or equivalent. Contact Xetec, Inc., 2804 Arnold Rd., Salina, KS 67401, (913) 827-0685 for further information.

All express and implied warranties for this product including the warranties of merchantability and fitness for a particular purpose, are limited in duration to a period of one year from the date of purchase, and no warranties, whether expressed or implied, will apply after this period. Some states do not allow limitations on how long an implied warranty lasts, so the above limitations may not apply to you.

If this product is not in good working order as warranted above, your sole remedy shall be repair or replacement as provided above. In no event will Xetec be liable to you for any damages including any lost profits, lost savings or other incidental or consequential damages arising out of the use of, or inability to use such product, even if Xetec or an authorized Xetec dealer has been advised of the possibility of such damages, or for any claim by any other party.

Some states do not allow the exclusion or limitation of incidental or consequential damages for consumer products, so the above limitations or exclusions may not apply to you.

This warranty gives you specific legal rights, and you may also have other rights which may vary from state to state.

Table of Contents

Introduction.....	1
Inventory	
Precautions	
Installation.....	7
Installing the 60E, 150E	
Installing the 60I, 150I	
The Tape Drive.....	13
Media	
Care of Media	
Cassette Loading/Unloading	
Write Protect Tab	
Cleaning	
Data Archiving.....	17
Using the X-stream Utility	
Backing-up Data	
Incremental Backups	
Restoring Data	
Verifying Data	
Tape Commands	
The Archive Bit	
Miscellaneous	
Troubleshooting.....	27
Troubleshooting Guide	
Customer Service	
Equipment Return Policy	
Updates and Errata.....	31
Obtaining Updates	
README Files	
Bug Report Form	
Specifications.....	33
Index.....	34

INTRODUCTION

- *Inventory*
- *Precautions*

Congratulations on purchasing a *FastTape* streaming tape drive, the first high-speed, low-cost tape backup for your Amiga® computer. Here's an overview of its features:

- Works with any hard drive that operates with AmigaDOS!
- High archive speed (up to 5 Megabytes per minute, depending on the hard drive used)
- Up to 60 or 150 Megabytes of storage on each tape (depending on model)
- Backs-up/restores data on file-oriented basis, allowing access to individual files
- Drive enclosure has its own power supply (*FastTape* models 60E and 150E only)

To use the *FastTape* drive on an Amiga®, you will need a Xetec SCSI host adaptor. For the 2000, a *FastCard* host adaptor is needed; for the 500 and 1000, a *FastTrak* or *FastTrak jr.* is required. A host adaptor made by someone else cannot be used to attach the tape drive to your computer. If you already have a Xetec host adaptor (that came with a Xetec hard drive), you can use it to access the *FastTape* streaming tape. If not, you will need to purchase the appropriate Xetec adaptor for your computer.

The host adaptor is basically an interface between your computer and the streaming tape drive. It generates a special set of signals that the tape drive understands. These signals conform to the SCSI (Small Computer Systems Interface) standard which is commonly used by many storage devices. This makes it easy to add more drives or other devices. (By the way, pronunciation of "SCSI" is divided between "scuzzy" and "sexy," so pick a side. Rest assured that neither is a very accurate description of the SCSI format.)

Inventory

Before doing anything else, identify the components included in your *FastTape* drive system.

FastTape models 60I and 150I

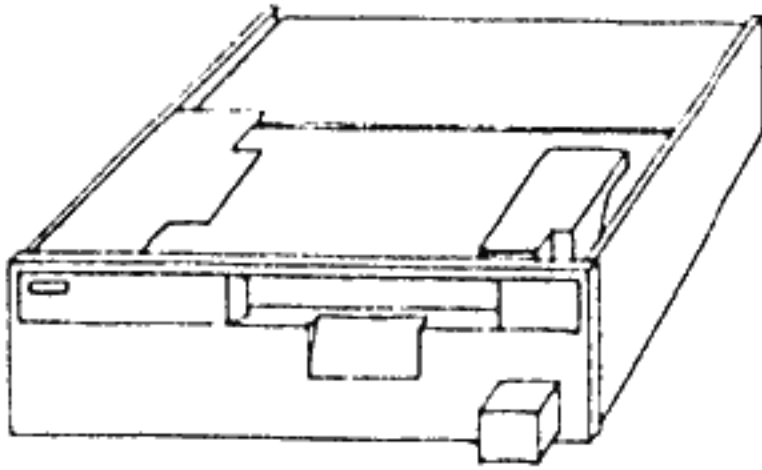

Tape Drive (60I)

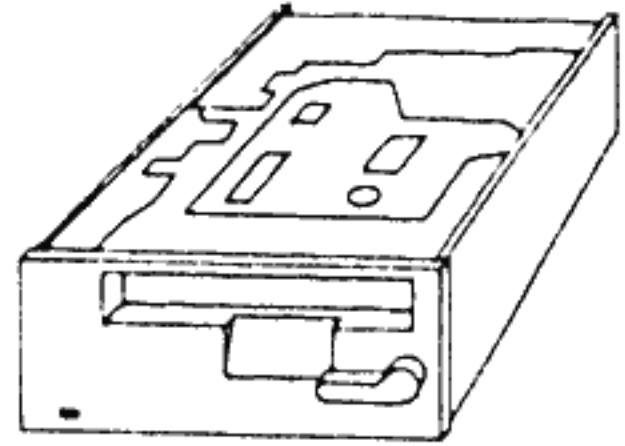

Tape Drive (150I)

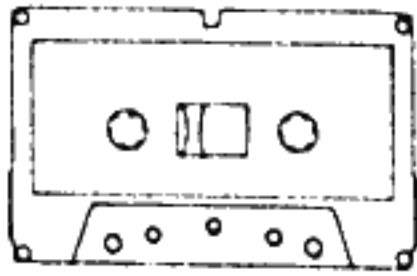

Data Tape



Hardware

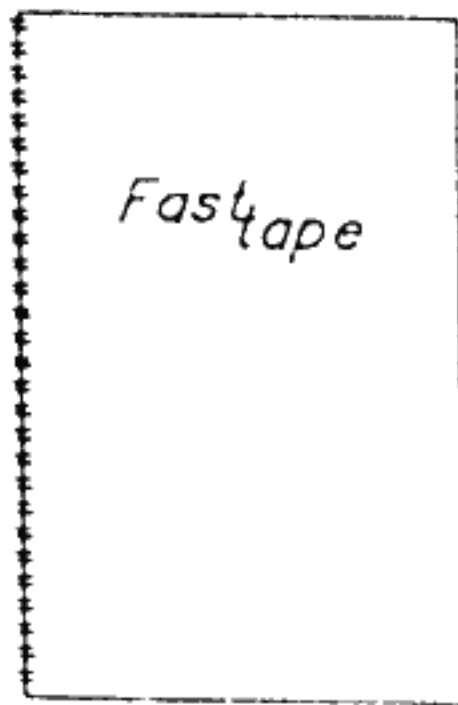

Manual

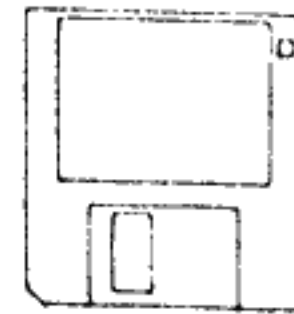

Utility Disk

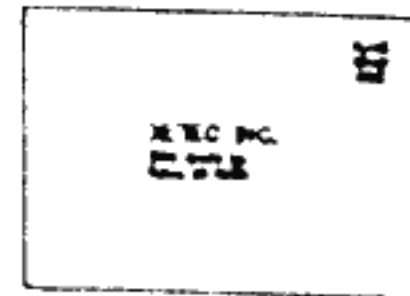

Warranty Card

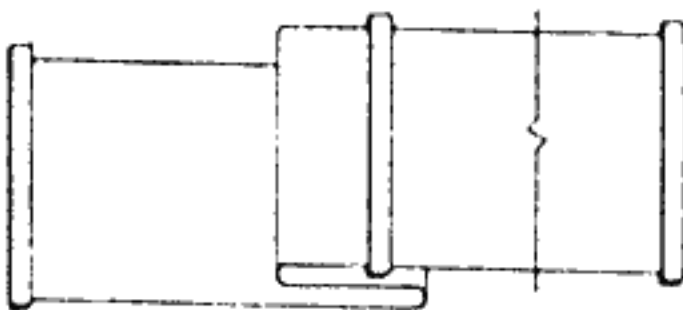

Ribbon Cable

FastTape models 60E and 150E

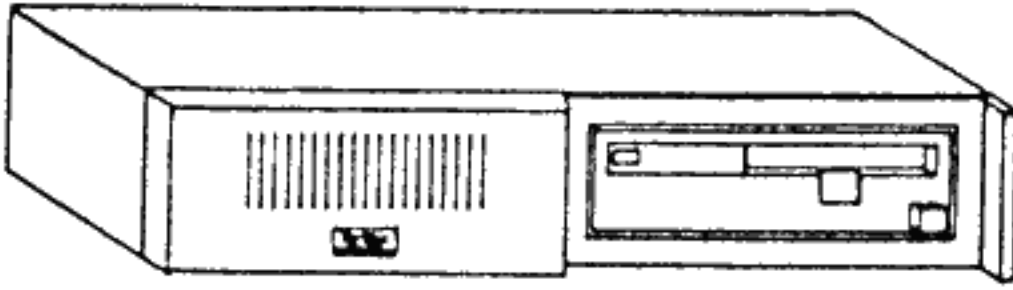

Tape Drive

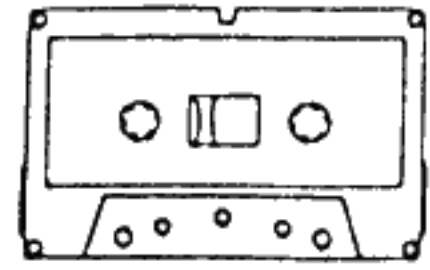

Data Tape

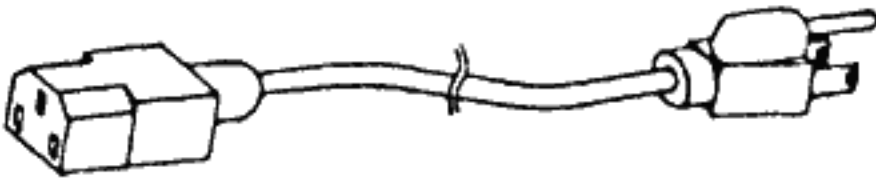

Power cord

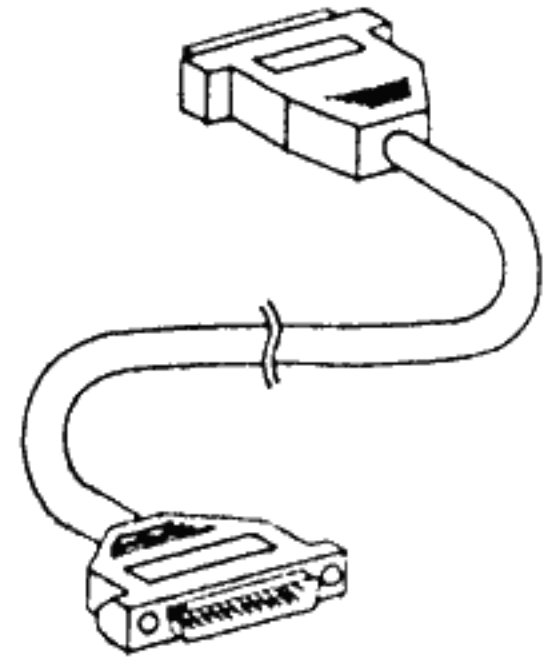

SCSI data cable

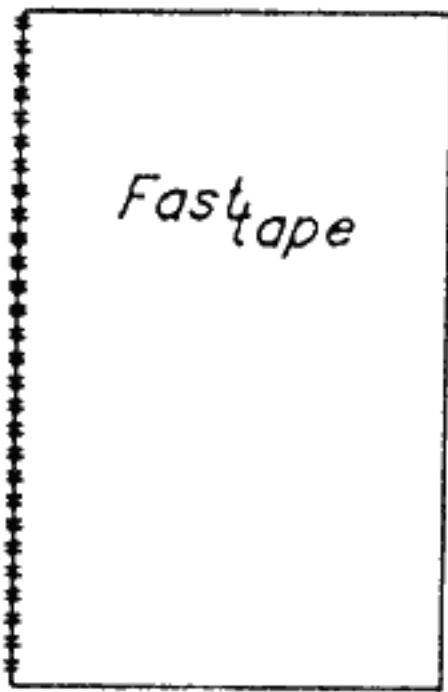

Manual

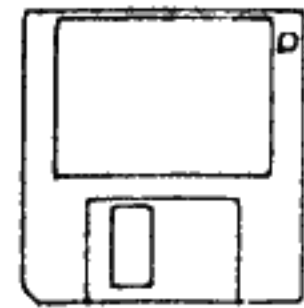

Utility disk

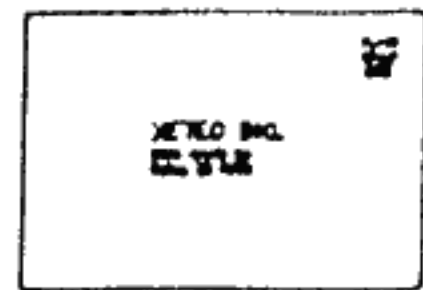

Warranty card

Precautions

Your *FastTape* drive has been designed to make installation a breeze. Nevertheless, read this manual very carefully, paying particularly close attention to the first few chapters. You're gambling with the future of your data if you skim these important sections!

A danger when installing the *FastTape* drive is static discharge. Before handling or installing the system components, you should prepare yourself so that you do not damage them by your touch. First, a carpeted floor is always dangerous! Leather-soled shoes also seem to be a problem. Static problems multiply when the humidity is low (generally in winter). A good rule to remember is any time you have walked any distance, discharge yourself before touching your computer or any peripheral. Large metal objects (such as a table) are a good place to discharge, as is anything connected to earth ground (like the screw in the cover of a wall socket).

INSTALLATION

- *Installing the 60E, 150E*
- *Installing the 60I, 150I*

Following are lists of the steps for installing all four models of *FastTape* drives: the 60E and 150E external tape drives mounted in their own chassis, and the 60I and 150I internally mounted tape drives for the Amiga 2000. Installation takes only a few moments, but must be done carefully to avoid damage. Be gentle, and work slowly, referring to the text frequently as you go.

Both drives require a Xetec host adaptor in order to operate. The steps below assume this host adaptor is already installed. For people using a *FastTrak* or *FastCard* series Xetec hard drive, this is already done. If you purchased a stand-alone Xetec host adaptor for use with the tape drive, install it using the supplied instructions before proceeding.

Installing the 60E, 150E

- 1) Make sure your computer, hard drive, and all other peripherals work correctly before installing the tape drive. This will prevent a misdiagnosis of other problems.
- 2) Make sure power is completely turned off to all components of your computer and hard drive system.
- 3) If you are installing the tape drive on an Amiga 500 or 1000, you must remove the tape drive's terminators. First, remove the four screws on the bottom that fasten the drive enclosure's cover. Remove the cover by sliding it toward the front of the chassis. Remove the four screws on the bottom that hold the tape drive in place. Turn the drive upside-down and locate the socketed terminators (a 20 pin DIP pack on the 60E, two 11 pin SIP packs on the 150E). Carefully remove (and save them). Reverse the procedure to reassemble the chassis.
- 4) Locate the 25 pin connector on the rear of the Host Adaptor (on the 2000 this is the vertical connector that sticks out the back of the computer), if a cable is already plugged into it, remove it. Now take the cable included with your tape drive and plug one end into this connector. Secure the cable with the attached screws.
- 5) Attach the other end of the cable to the connector marked "Host Adaptor" on the back of the tape drive's chassis. See Fig. 2. Again, secure the cable with the attached screws.

- 6) If you have an external hard drive (that you disconnected in step 4) plug the free end of its data cable into the connector marked "Add-on drive" and tighten the screws.

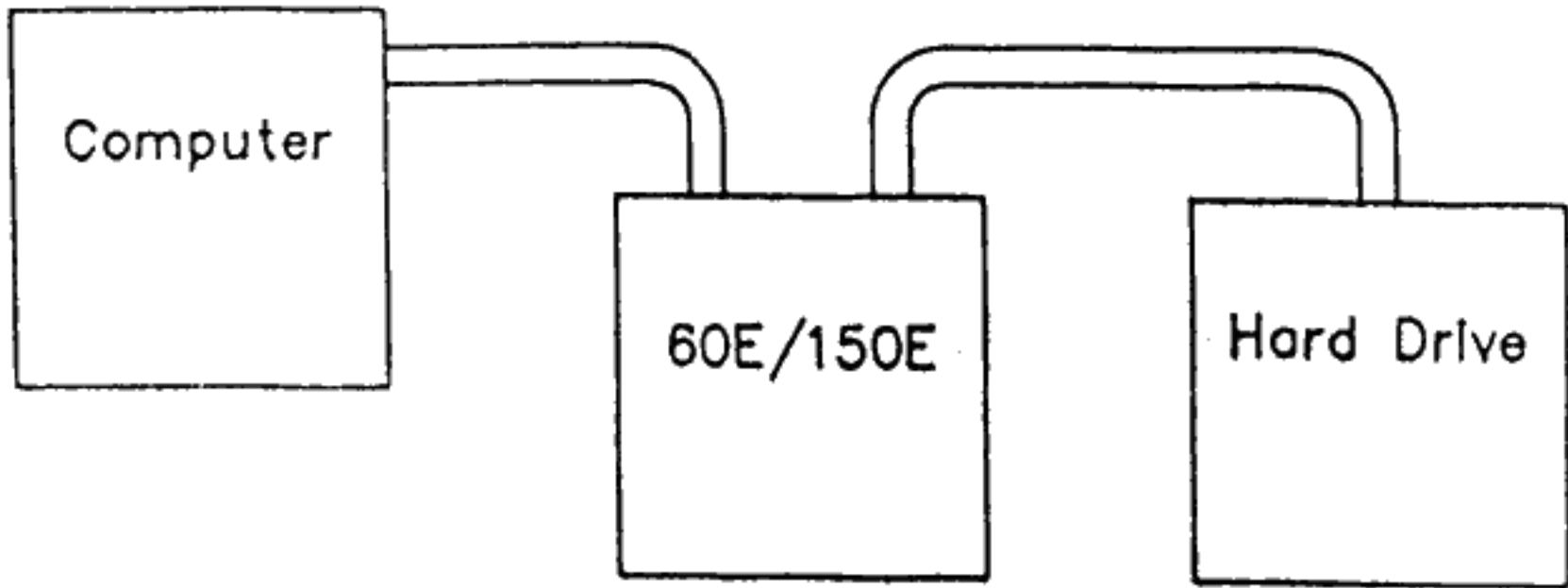

Fig. 2 - 60E, 150E Connections (w/external drive)

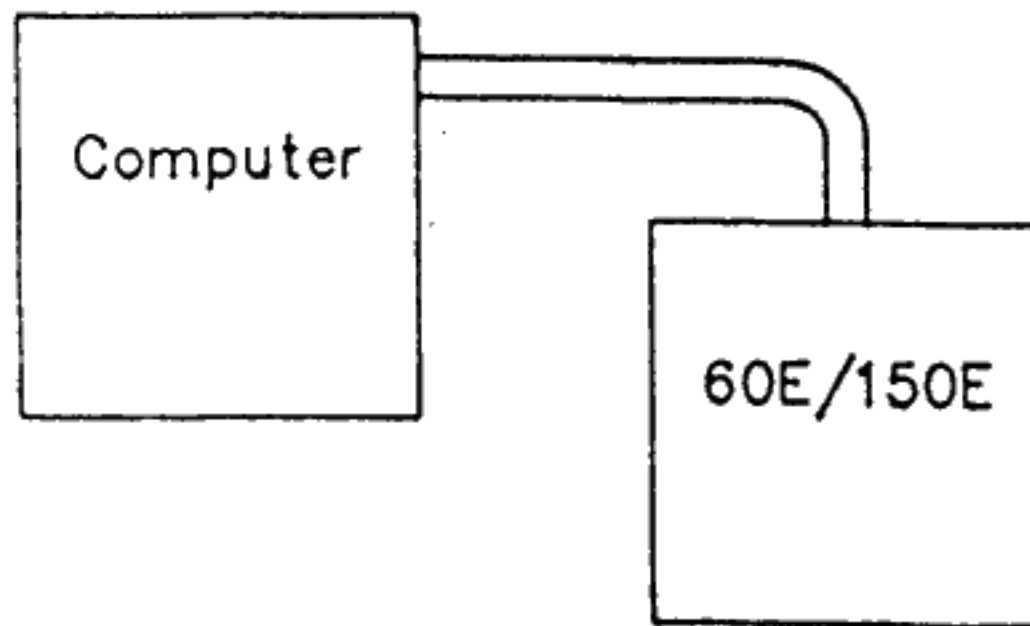

Fig. 3 - 60E, 150E Connections

CAUTION!

Unless your *FastTape* chassis is labeled otherwise, it has been factory wired for:

115 volts A.C. 60 Hertz

Do not plug the power cord into any other voltage or frequency outlet.

For domestic American systems, the correct outlet type is the three prong grounded variety. Use of a three prong adaptor in a two prong ungrounded outlet is strongly discouraged since such use presents a high shock hazard and may damage your system.

- 7) Locate the AC power cable and plug the female end into the 115 VAC receptacle at the back of the tape drive enclosure. Be absolutely sure it's pushed in **all the way**. Make sure the Power Switch is in the OFF position and plug the male end into a properly grounded 115 volt AC, 60 Hz outlet.

Installing the 60I, 150I

- 1) Make sure your computer, hard drive, and all other peripherals work correctly before installing the tape drive. This will prevent a misdiagnosis of other problems.
- 2) Make sure power is completely turned off to all components of your computer and hard drive system.
- 3) Unplug the keyboard and mouse connectors from the front of the computer.
- 4) Remove the 5 screws that fasten the computer's cover—two on each side and one in the rear (it's the screw just next to the two slot covers). Remove the cover by pulling towards the front of the computer and upward. Set it aside.
- 5) Find the ribbon cable included with the tape drive. Plug the middle of the three connectors into the connector at the rear of the tape drive unit, so that the red stripe on the cable is closest to the center of the drive on the 60I and closest to the white 4-pin power connector on the 150I.
- 6) Model 60I mounting: feed the drive's ribbon cable into the lower drive bay. Pull it out the back of the bay as you carefully guide the tape drive into the slot. Remember that delicate parts are probably exposed on the drive's bottom. Secure the drive in place with the four screws (two on each side). If installed properly, the drive should be suspended a little above the bottom of the metal in the drive bay. Remove the insert in the cover to provide access to this lower slot. Temporarily install the cover to test the fit. Remove the cover and tighten the screws when all fits well.

Model 150I mounting: the mounting plate in the upper bay that the drive will rest on must first be detached. To do this, remove the

four screws holding the plate in place and lift upward. Position the tape drive on the plate and insert the four *included* mounting screws (do not tighten). Carefully lower the plate back into place. Remove the insert in the cover to provide access to this new bay. Temporarily install the cover to locate the correct position for the tape drive. Remove the cover, lift the plate, and tighten the drive's mounting screws. Once again, install the drive plate and replace its four screws.

- 7) Neatly route both loose ends of the ribbon cable towards the Xetec *FastCard* host adaptor.

If this card has no drive on it, simply plug one end of the ribbon cable onto the 50-pin header at the rear of the board, making sure the red stripe is at the top!

If the host adaptor card has a hard drive installed, remove the cable connecting the drive to the card. Plug the two free ends of the tape drive's ribbon cable into these two connectors you just freed up. It doesn't matter which cable is plugged into which—just make sure the cables will lay neatly. The red stripe must be at the top for both connectors!

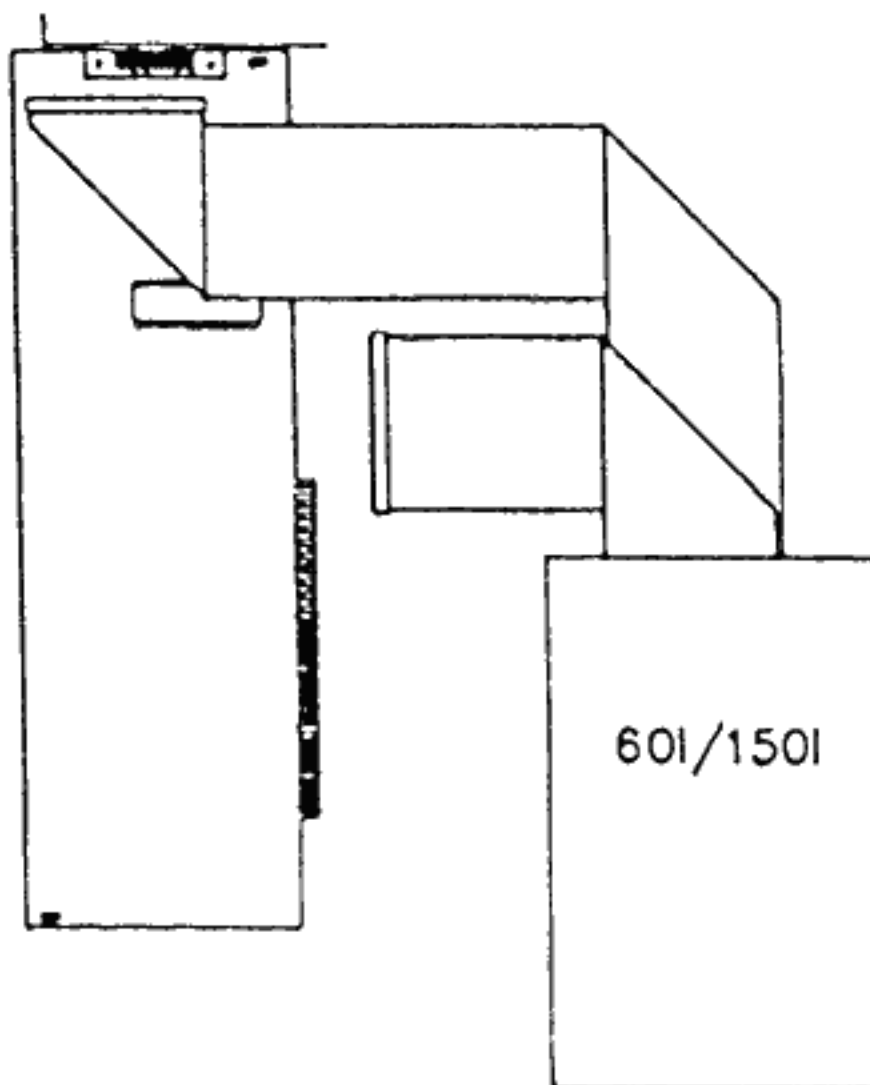

Fig. 4 - 60I, 150I Connections (w/o drive)

- 8) Find a free 4-wire power connector on a cable coming from the power cage. Plug it into the back of the tape drive (notice that two of the corners are beveled for correct insertion).
- 9) Replace the computer's cover and the five screws. Replace the keyboard and mouse connectors.

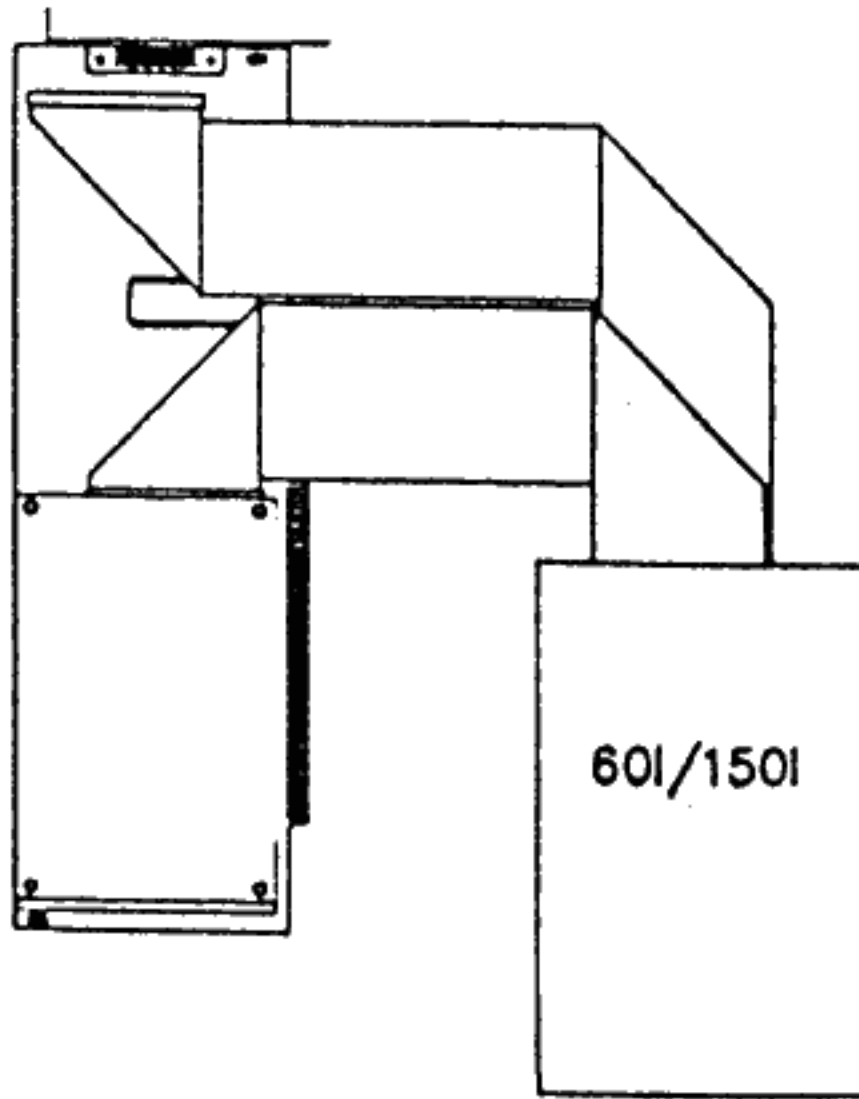

Fig. 5 - 60I, 150I Connections (w/internal drive)

THE TAPE DRIVE

- *Media*
- *Care of Media*
- *Cassette Loading/Unloading*
- *Write Protect Tab*
- *Cleaning*

Media

The magnetic media to be used in your tape drive is as follows:

Models 60E, 60I: TEAC CT-500H or CT-600H tapes (comply with D/CAS-12)

Models 150E, 150I: TEAC CT-600N tapes (comply with D/CAS-86)

These tapes are available from Xetec and its dealers.

Care of Media

Observe the following precautions for the handling and use of your data cassettes.

- 1) Keep tapes in their plastic cases at all times when not in use.
- 2) Never touch the surface of the tape with your fingers.
- 3) Before removing a tape from the drive, rewind it to the beginning leader (using the included software).
- 4) Avoid operating or storing the cassette in a smoky or dusty environment.
- 5) Avoid strong magnetic fields (motors, magnets, transformers, etc.)
- 6) Avoid exposure to direct sunlight (for the cassette, that is — suntanning is okay).
- 7) Never exceed the recommended storage conditions for the tape:
Ambient temperature — 4 to 50° C (39 to 122° F)
Relative humidity — 20 to 80% noncondensing

If these precautions are followed, the life expectancy of a tape should be 1000 to 2000 passes (one pass being one round trip — from the beginning of the tape to the end and back).

Cassette Loading/Unloading

Process for installing a data cassette into the tape drive:

- 1) Hold the cassette so that the screws are on the top side and the tape opening is to the left.
- 2) Insert the tape into the drive's opening, pushing the tape in as straight as possible.
- 3) When the tape is nearly in, it will be "grabbed" by the mechanism and completely loaded.
- 4) On tape drive models 150E and 150I only, you must then twist the lever on the front panel to the right (clockwise) until it points straight up.

To remove a data tape from the drive:

For models 60E, 60I: Push the eject button in the lower-right corner straight in.

For models 150E, 150I: Rotate the lever counter-clockwise until the tape pops out.

Caution: avoid ejecting the tape when it's running (the front panel light is on).

Write Protect Tab

Just like floppies and audio tapes, the data tapes have a device for protection from accidental erasure. Normally, a small red piece fills a hole on the side of the tape. See fig. 6. In this state, the tape may be read, written, or erased. To write-protect it, remove the red tab with a small screwdriver and save it. Notice that there are two similar holes on the side of each tape. The only one that matters is the one nearest the arrow that says "THIS SIDE IN". The other hole can be used to store the tab when it needs to be removed (for write-protection).

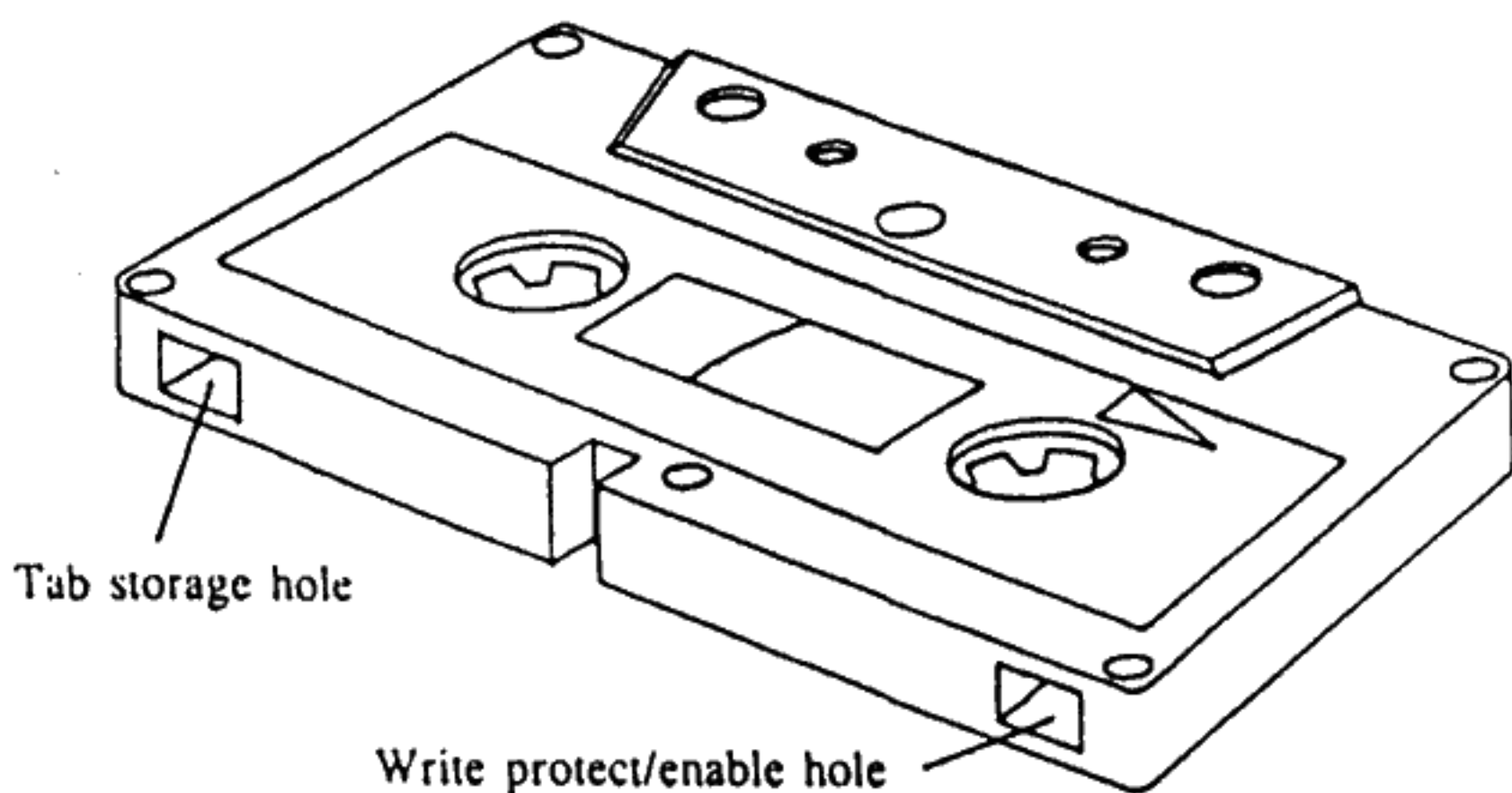

Fig. 6 - Write protect tab

Cleaning

To maintain data reliability, the tape drive should have its read/write head cleaned once per month or after 200 passes (one pass being a complete loop from beginning of tape to end and back). The cleaning interval may be shortened or lengthened if the operating environment is exceptionally dirty or clean, respectively.

The process used to clean the head is similar to that for cleaning an audio cassette head: use a Q-tip and denatured rubbing alcohol (also found in video head cleaning kits). Moisten the tip in the alcohol, open the tape door, and clean the head's entire surface. The head is a dull gray and is located half-way back in the tape slot on the left side (almost recessed).

A cleaning kit designed specifically for your tape drive is available. Contact Xetec or your nearest dealer for kit TZ-380.

DATA ARCHIVING

- *Using the X-stream Utility*
- *Backing-up Data*
- *Incremental Backups*
- *Restoring Data*
- *Verifying Data*
- *Tape Commands*
- *The Archive Bit*
- *Miscellaneous*

A very important part of owning a hard drive is archiving, or backing up, the data it contains. Hard drives are designed to be as trouble-free and foolproof as possible, but the possibility of mistakes, power failures, sabotage, etc. is just too great to risk your data. Our goal is to make archiving so easy and quick that it becomes a habit.

Unlike other SCSI devices, the tape drive cannot be accessed directly from AmigaDOS with a device name. It can only be used from the archive utility called **X-stream™** located on the included utility disk.

Using the X-stream Utility

Before starting the program, you should consider the computer's resources for a moment. Even though the Amiga is a multi-tasking computer, for maximum speed and convenience don't waste a lot of memory and processor time on other tasks when using **X-stream**. When too much processor time is used for other things, the tape drive will begin to "shuttle" the tape back and forth instead of using a continuous motion. This will dramatically increase the time required to complete the backup/restore. So be kind and give **X-stream** full use of your Amiga's power when doing data archiving.

Now let's use the program. But first, you need to know what model of tape drive you have. The program can be run in two different modes: one for model "60" tape drives, and another for "150" models. To start the program, double-click on the appropriate icon (**X-stream 60** or **X-stream 150**). From a CLI or shell, you can start the program by typing its name followed by the mode. For example,

```
X-stream 150
```

After a few moments, the **X-stream** window should appear (see fig. 7). Notice that the title bar shows the mode the program is running in (60 or 150 Meg).

Let's spend some time and get familiar with several features of this window before actually transacting any data. Under the *Project* menu is the *Quit* selection. Use it to exit the program.

The large block box is an area where directories are displayed. Notice that right now all of the file-oriented devices AmigaDOS currently sees are displayed. Pick one of them by clicking on it with the mouse and left button. Notice it becomes highlighted. Now click on the box near the bottom marked "Get Dir." After a short pause (depending on the device) the root directory of the device you selected will be displayed in the file area. Another way to do this same thing is to double-click on the name in the file box. If more files exist than can be displayed in the box, you can scroll through the list using the scroll gadget just to the left of it. (Use it like other Amiga scroll gadgets: drag the white bar or click above or below it to move your view up or down.)

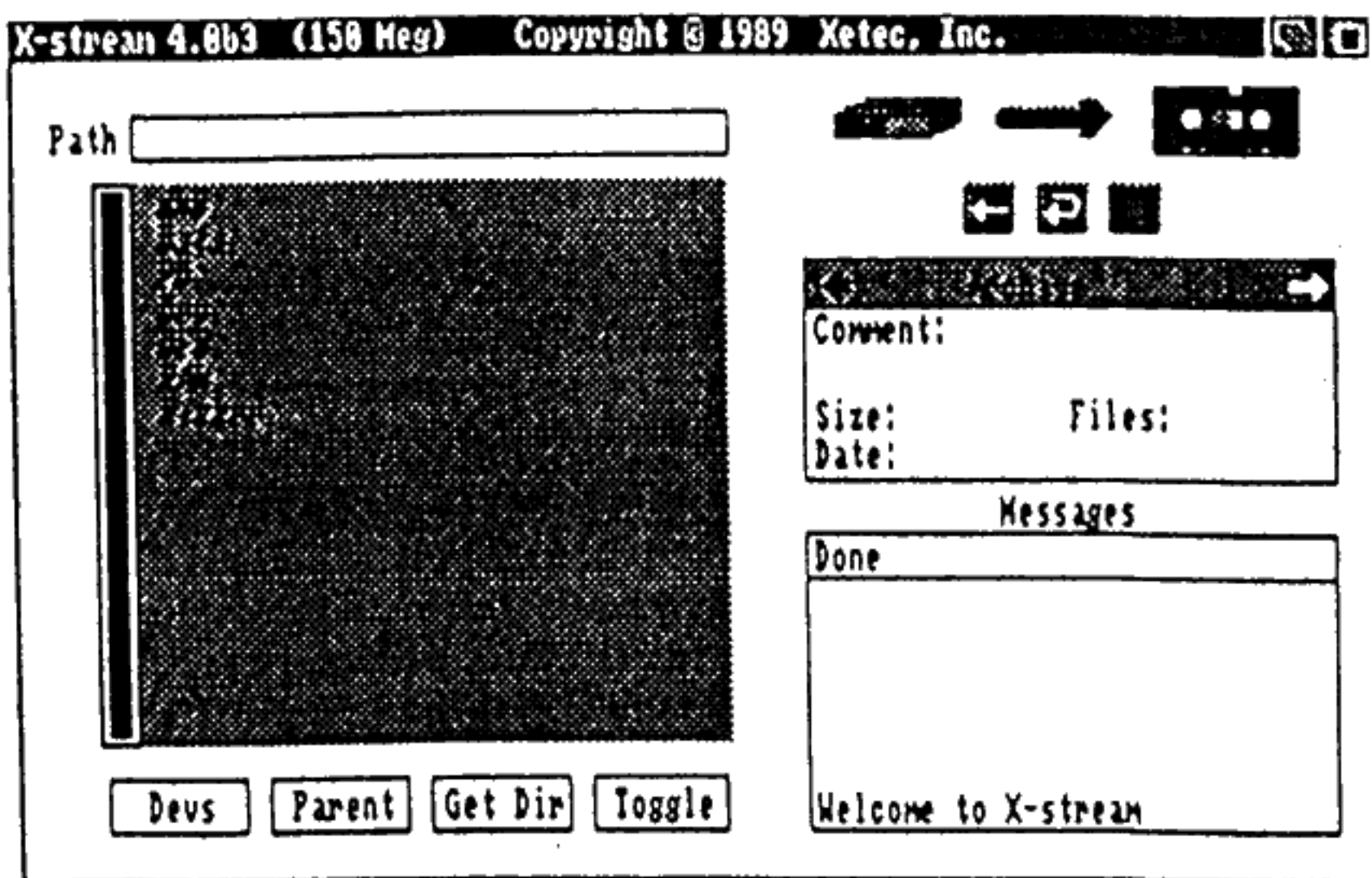

Fig. 7 - X-stream window

Notice the other three commands below the file box. **Devs** goes back to the list of AmigaDOS file devices. **Parent** displays the directory just above the one displayed. If the root directory of a device is currently shown, **Parent** will go back to the list of devices. **Toggle** will change the select status of all files in the list (it will highlight all those that aren't and vice versa). This will be useful later when actually backing up and restoring data.

Just above the file box is a box marked **Path**. It shows at all times the device and directory level currently displayed in the file box below it. For example, if it shows

df0:devs/fonts

then the files displayed are in the "fonts" sub-directory of the "devs" directory of the disk in the first floppy drive. You can type directly into the path box if you want by clicking in it. As soon as you hit RETURN, the file box will attempt to display the directory path you supplied. Normally, you should never need to enter the path directly.

The box in the lower-right of the window is a message area. Several types of messages can appear here—informative messages, names of files being copied, and error messages. The top line of the message area displays status messages telling what's currently happening.

Above the message box is another box that contains the archive information. The black strip at the top of the box symbolizes the magnetic tape. On it are several symbols that allow you to manipulate the tape. The information in this box will

be discussed in detail when you learn to backup and restore data. Three buttons are found just above the archive info box. These do even more things with the tape (you guessed it, to be discussed later).

In the upper-right are images of a hard drive and a cassette tape. Clicking on the arrow between them will initiate a backup operation (don't do it now). Notice that only a backup is available. How do you restore or verify data on the tape? If you display the tape's files in the black file area (you'll see how later), then two new orange arrows will replace the backup arrow—one to restore and one to verify. So the action you are allowed to take depends on what files you have displayed and selected in the file box.

Backing-Up Data

Ready to backup some files? First, insert the tape into the drive. The label on the tape tells which side should be on top—never try to "use the other side." With the tape exposed on the left side, slide the tape in until it pops inside. For "150" models, you must also twist the lever to the right until it's vertical.

Before writing to the tape, we must format it, just like a floppy. Click on the erase icon



and answer the requester. The tape's light should come on and the status line should say "erasing tape..." After a couple of minutes, the tape should be successfully formatted (status "Done").

Now let's backup some files. First, give this backup a label: click in the archive info box just below the word "Comment." A cursor should appear; type in a phrase such as "A test backup on March 9" or something. You can type as many as 80 characters (it will scroll left and right). When done, press RETURN. This comment is stored along with the files in the backup and will help you remember later something about the backup.

Now display the files of some device (preferably a hard drive) in the file box. Then highlight each file or directory that you want to be involved in the backup. Remember you can click Toggle to select all the files. Click on the backup arrow (the one pointing to the tape). A window should appear warning you of what you are about to do. You also have several options you can change in this window: Files, Subdirs, and Archive bit. To change the setting of one of the options, just click in its box and the new setting appears in the box. Let's discuss each of the options quickly:

Files: this option allows you to save time by only backing up those files which haven't already been backed up or are new (have changed since they were last backed up). The two choices are "All" or "New."

Subdirs: This option only affects the contents of directories that are highlighted for backup. With the option turned off, only the files contained in the directories are considered for backup. With the option turned on, all subdirectories in the highlighted directories will also be considered for backup (and their files and subdirectories, and so on).

Archive: each file contains an archive bit that keeps track of the status of the file—backed up or not. If this option is set to "Set," every file backed up will be marked as "backed up." With the option set to "No," no files will have their archive bits changed, even ones that *are* backed up.

For now, make sure the archive option is set to "No." When you are ready, click the box marked "Do it." You can select "No!!!" if you don't really want to backup the files. When you are ready, click the box marked "Do it." All eligible files will now be copied to tape in the following manner. When "Reading..." appears in the message box, the files are being read from their source (such as the hard drive). When "Writing..." appears, the name of each file will be printed as its written to the tape. Watch the names fly by! Depending on the number of files to be backed up and the amount of available memory, this reading/writing cycle may repeat several times.

When the backup is complete, "Done" is printed and the tape stops, ready for another backup.

Incremental Backups

A very good habit to form is to make frequent *incremental* backups of your hard drive data. An incremental backup only copies files that have been created or changed since you last backed-up the drive. This type of backup is quicker and takes up less tape storage than a complete backup. To do an incremental backup, just use the "New" option when you do a backup. The first backup should be an "all" backup with the archive "Set" option.

Since incremental backups only copy the new files, you must keep on hand all sets made from the drive. Only when you do a complete (*ALL*) backup should you dispose of older archive sets for that partition/directory.

Restoring Data

Hopefully, you should rarely have to restore data back to the hard drive from tape. You can use a restore to completely reconstruct a directory or partition after a catastrophe or to simply recall an old version of a single file.

Let's pretend you lost the files that you backed up earlier. The first step in retrieving files from tape is to find the archive on tape (one tape can contain many backup sessions). Several tools are available to allow you to find specific archives. Here are the archive search tools in the archive info box:



1st archive: positions the tape at the first archive recorded on the tape.

Prev archive: moves the tape to the archive just before the one we are currently at.

Current archive: the archive number the tape is currently positioned at.

Next archive: moves the tape to the next archive on the tape.

End of data: moves the tape to the first free spot on the tape (in order to add more archives to a partially full tape).

We know that the archive we want is the first on the tape; so click on the **1st archive** tool. As soon as that archive is found, the archive info box is filled in with the data for that archive including the comment that was provided (if any), the total size of all the files in the archive, the number of files, and the time/date of the backup.

When an archive is found with these tools, a pseudo-device called **TAPE:** then becomes accessible from the file box. Click on **Devs** to see a list of the devices. Now, this **TAPE:** is not a true AmigaDOS device, but within **X-stream**, it acts just like a real device.

Call up a list of the files by highlighting **TAPE:** and selecting **Get Dir**. The files backed up should now be displayed. You can use **Get Dir** and **Parent** to delve into the sub-directories in this archive. Highlight the file or files you want to restore and click on the restore arrow (points to the hard drive).

The restore options window should now appear. This is just like the one for backing up except for two additions: the **File Destination** box and the **Mode:** option. The file destination box allows you to choose where the files will be written to during the restore. It defaults to the place where they came from, but you can always divert them elsewhere. To avoid any catastrophe, let's not restore the files back to the hard drive right now; a safer destination for your first test is the ram disk. Click in the file destination box, delete the path listed (if any), and enter **RAM:** and **RETURN**.

Four options are available when restoring files. Although three of them look the same as backup options, they can be set independent of the backup option settings.

Files: just like the backup option, this can be set to "All" or "New." For restore, the "New" mode will only restore a file if it isn't present in the destination path. If a copy already exists, the file will only be restored if it's newer than the one in the destination path.

Mode: This option can take one of two states: Tree and List. In the tree mode, all files are restored just as they were retrieved (tree referring to the structure of sub-directories). The "List" mode restores all files into the same directory, which is the file destination path, regardless of the sub-directory level from which they came.

Subdirs: this option works just like the one for backup.

Archive: this works similar to the option in backup, but the archive bit in question is the destination file's (instead of the source file's, as was the case for the backup). Normally, use "Set" because file's restored from tape are still backed up (unless you restore the files, then erase the tape).



Verifying Data

To compare the files in a tape archive with those on a disk, you follow very much the same procedure as when restoring files. First find the desired archive on tape to work with, get a directory of the files in the archive, highlight the file(s) to verify, click on the verify arrow (the one with the circle and "?"), select the desired options and the path where the files to compared can be found, and select "Do it."

Each file's name is printed as it is verified. "Error!" will be printed for files that do not verify. When done, the total count of verify errors is displayed. If the files scroll by too fast, they can also be viewed in a window underneath X-stream called "X-stream messages." You can slow down the verify process long enough to read the results by clicking in this window and using the right mouse button to pause it.

Tape Commands

Three more commands are available for manipulating the tape. These are low-level commands, in that they are more primitive than the backup/restore and tape positioning features.

-  **Rewind** - completely rewinds the tape and stops, leaving it positioned at the leader. Use this command before ejecting a tape to keep from exposing the recordable surface.
-  **Prewind** - forwards the tape to the end, then completely rewinds it, leaving it positioned at the leader. Prewinding "evens out" the tension, which is a wise thing to do before using tape that has been sitting idle for some time.
-  **Format** - completely erases the contents of the tape and prepares it to hold data. This operation, just as for floppies, is necessary in order to write to a new tape. This command is also used to blank a tape that already contains data.

The Archive Bit

Every file on your floppies or hard drive has a special flag called the *archive bit*. Its purpose is to flag whether or not that file is currently backed-up. You can view this flag with the list command, which will display something like

SomeFile	867 ---arwed Today	09:25:53
AnotherFile	105 ----rwed Today	11:17:29

In this example, *SomeFile* is backed up, but *AnotherFile* is not. The archive bit is instrumental in doing incremental backups. X-stream both sets and senses these bits depending on the options selected. When a file is backed up or restored, its archive bit is usually set, indicating "I'm backed up elsewhere." The way a file's archive bit usually becomes cleared is when you modify or rewrite the file. Also, when you create a new file, its archive bit is not set (because it hasn't yet been backed-up). X-stream gives you the ability to examine and modify archive bits easily.

The way you can tell the status of a file's archive bit is by the color of the file's name in the file box. All file's which are backed up (archive bit set) appear in white. All other files (archive bit not set), appear orange.

You can change the state of archive bits by highlighting the files and/or directories to work with and selecting one of the menu options under **File Status**. Select **Archived** to set the archive bit in all the files selected, or **Not Archived** to clear their archive bits. All files and sub-directories contained in a highlighted directory will also be affected.

A few directories cannot have their archive bits changed (ones that have an assign on them, such as sys:c). All the files contained in them can be affected, just the directory heading can't.

The only time you should need to directly set or clear any archive bits is when you want to "fool" the backup/restore programs. A good example is a developer of C code who copies all the files from his distribution disks onto the hard drive. To keep from having them backed up (which isn't necessary — they can be retrieved off the distribution floppies), he would highlight the files that came off the disks and select "Archived" under "File Status." X-stream will then not backup the files to tape (as long as the "New" option is used).

Miscellaneous

When archiving multitudes of very small files, especially with model "150" tape drives, it is quite possible that the software won't be able to move enough files fast enough to keep up with the tape (thus the tape will "shuttle"). Tape shuttling is OK, but time consuming. If you have a batch of files that consistently are a problem, try turning message box scrolling off by selecting the menu selection Options/Scroll. (This is an on/off switch, look for the checkmark to see if it's on.) Without scrolling it's more difficult to watch the progress of the backup/restore, but the time saved can be significant enough to handle the smallest of files without shuttling.

TROUBLESHOOTING

- *Troubleshooting Guide*
- *Customer Service*
- *Equipment Return Policy*

Troubleshooting Guide

Symptom	Possible Cause
External drive won't work	Power cord not seated fully in back of drive Bad outlet Blown fuse in back of chassis
Computer won't boot	Improper cabling/host adaptor
System locks up when accessing tape drive	Illegal SCSI bus Improper SCSI terminators Data cable not screwed on at both ends
Tape periodically stops	Too many other programs running

Customer Service

If you have a problem that is not covered in this manual, you may obtain help by calling customer service at (913) 827-0685 between 10 a.m. and 4:30 p.m. CST. We cannot help those who have not read this manual. Before you call, find the revision of your *FastTape* floppy (see its icon or disk name) This is likely to be vital in our solving your problem.

If you discover a bug or would like to make recommendations or comments, use the bug report form on p. 32. Please leave our service lines open for those who need answers. Bug report forms are also more quickly and easily routed to those who need to see them.

Xetec also has a bulletin board in operation to provide support for all *FastTape* owners. The number is (913) 827-1974.

Equipment Return Policy

Do not return any system or part thereof unless you have first called and received authorization. Any hardware to be returned will require an RMA (return materials authorization). Any hardware without an RMA number clearly marked on the outside of the box will be refused. Call (913) 827-0685 to obtain an RMA.

When shipping a drive, be sure to use the original carton. Include a letter describing the problem and proof of purchase, if under warranty.

The drive's warranty will only be honored if the registration card has been completed and mailed in.

UPDATES AND ERRATA

Obtaining Updates

To be notified of important system updates, you must be registered with Xetec. To do this, you should complete your registration card and mail it in. Certain enhancements and/or bug fixes are bound to follow. Depending on the nature of the update, a minimal charge may be required.

README Files

Any up-to-the minute changes that don't make it into the manual will appear in these text files, located on the *FastTape* utility disk. They may also contain hints or caveats. To read the files, either use

`type readme`

from CLI, or from Workbench™ double-click on its icon.

Bug Report Form

Unfortunately, even the most refined programs can contain bugs. The most common bug is the one that occurs with a specific combination of hardware and usage that was never foreseen or tested. We have made every effort to eliminate all such bugs. If you discover what you think is a bug, please report it as soon as possible on a copy of the following form. We truly wish to make the *FastTape* system error-free, and will give every formal bug report close and careful consideration.

If you find multiple problems, please submit each on a separate copy of the form. A copy of this form is in the file *BugForm* which you may print and use (type >par: BugForm).

FastTape Bug Report Form

Date:
Name:
Company:
Phone: () -

Bug type: Hardware
 Software
 Documentation
 Other

Revisions: ___ Kickstart ROM or disk
 ___ Workbench
 ___ FastTape floppy disk
 ___ Program in question (if software)

Computer type _____
Memory _____

Other equipment _____

Bug description:

Bug generation procedure:

SPECIFICATIONS

Data tape capacity, formatted

CT-500H	50 Megabytes
CT-600H	60 Megabytes
CT-600N	155 Megabytes

	60E, 60I	150E, 150I
Standard	D/CAS-12	D/CAS-86
Average read/write speed	86,300 bytes/sec	116,200 bytes/sec
Tape speed	90 ips	90 ips
Number of tracks	9 serpentine	16 serpentine + dir
Recording density	7,670 bits/inch	12,800 bits/inch
Bytes per block	512	512
Form factor	5¼"	3½"
Retries	16	16
MTBF	8,000 hours	10,000 hours
Soft errors	once per 10 ⁷ bits	once per 10 ⁷ bits
Hard errors	once per 10 ¹⁰ bits	once per 10 ¹² bits
Power requirements (60I, 150I only)		
5 volts DC	1.1 amps	0.8 amps
12 volts DC	1.6 amps	1.3 amps

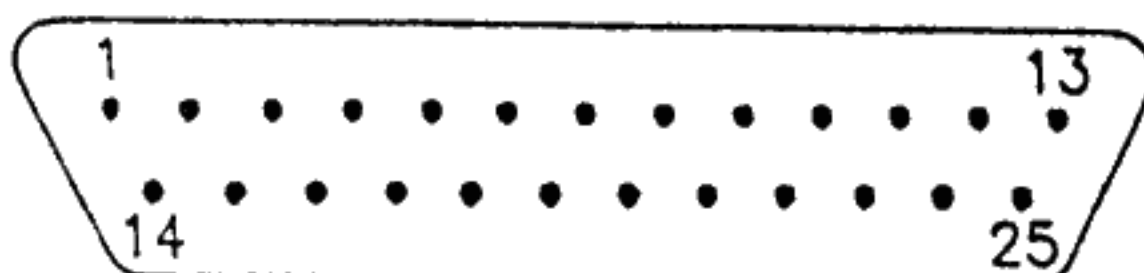

Pin	Name	Pin	Name
1	REQ	14	Gnd
2	MSG	15	C/D
3	I/O	16	Gnd
4	RST	17	ATN
5	ACK	18	Gnd
6	BSY	19	SEL
7	Gnd	20	DP
8	D0	21	D1
9	Gnd	22	D2
10	D3	23	D4
11	D5	24	Gnd
12	D6	25	
13	D7		

INDEX

Archive bit 24
Archive option 21,23
Backup 20,21
Cleaning 16
Comment 20
Devs 19
Ejecting 15
Erase 20,24
File box 18
Files option 20,23
Format 24
Host adaptor 8,10
Incremental backups 21
Media 14
Message box 19
Mode option 22,23
Parent 19
Path 19
Prewind 24
Primes 17,19,23
Restore 21,22
Rewind 24
Ribbon cable 3,10,11
Scrolling 25
SCSI 2
Static 5
Subdirs option 21,23
Tape 3,4,14,15
TAPE: 22
Terminators 8
Toggle 19
Verify 23
Write protect 15,16